

OPERATION, MAINTENANCE AND SPARE PARTS MANUAL

HYDRAULIC CRANE CR40



READ THIS OPERATION AND MAINTENANCE MANUAL CAREFULLY
BEFORE USING THE MACHINE

FARMI[®]
FOREST

Farmi Forest Corporation
Ahmolantie 6
FIN-74510 Iisalmi, Finland
Tel. +358 (0)17 83 24 400
info@farmiforest.fi
www.farmiforest.fi

CR40

TABLE OF CONTENTS

PRODUCT WARRANTY	6
GENERAL SAFETY INSTRUCTIONS	7
STICKERS AND PLATES	12
TECHNICAL DATA	13
MAIN COMPONENTS	14
ASSEMBLY AND MOUNTING	15
COMMISSIONING	16
PRACTICE RUNS	16
DETACHING THE CRANE	17
STORAGE INSTRUCTIONS	17
HYDRAULICS	18
CONNECTING THE ON/OFF VALVE	19
PRESSURE RELIEF VALVES	20
TESTING THE STABILITY	21
DETERMINING THE STAND-STABILITY BY CALCULATION	21
MAINTENANCE	22
TROUBLE SHOOTING	25
LUBRICATION	26
ANNUAL INSPECTION RECORD	27
INSTALLATION INSPECTION RECORD	28
200000575 CR40	30
200000535 SLEWING DEVICE AND COLUMN	32
200002521 LIFTING BOOM	34
200000533 FOLDING BOOM	36
200001719 ROTATOR CR300-W25A25	38
200001717 CROSS LINK, WITHOUT BRAKE	40
200001712 CROSS LINK, WITH BRAKE	41
200001715 CROSS LINK, WITH DUAL BRAKE	42
200002801 TIMBER GRAPPLE PTK021S / CR300	44
200001965 HYDRAULIC SUPPORT LEGS, 3-POINT LINKAGE	46
PRODUCT REGISTRATION FORM	50

When ordering spare parts, please indicate machines type from the machine plate, spare parts order number, description and quantity required. Example. CR40, 58204610, slide bearing 1 pc

WARNING SYMBOLS IN THIS MANUAL



- **imminent danger which could cause serious personal injury or death**



- **danger which could cause personal injury**



- **conditions or misuse that could damage equipment or machinery**

NOTE!

- **reminders, such as for performing checks or carrying out maintenance or repair procedures**

INTRODUCTION

This manual includes the information and maintenance instructions required for operating the machine in the optimal manner.

Although you have experience in using this kind of machinery, read the operation and maintenance instructions carefully since they include information enabling efficient and safe operation. Regular maintenance is the best way to guarantee the efficient and economical performance of the machine.



Each and every operator must read, understand, and follow all safety instructions and procedures.

CUSTOMER FEEDBACK

We are happy to receive your opinions and suggestions for improvements by mail, fax or e-mail. All implemented suggestions for improvements will be rewarded.



EC DECLARATION OF CONFORMITY
Original declaration of conformity

Manufacturer:

Farmi Forest Corporation
Ahmolantie 6, FIN-74510 IISALMI, Finland

Person authorized to compile the technical documentation:

Name: Matti Berg
Address: Ahmolantie 6, FIN-74510 IISALMI, Finland

Commercial name:

Farmi

Machine denomination:

Hydraulic crane

Machine type:

CR40

Machine series number:

Herewith, we declare that the machine brought into circulation conforms with the pertinent requirements of the Machinery Directive 2006/42/EC and the EMC Directive (directive relating to electromagnetic compatibility) 2004/108/EC.

The following harmonized standards have been applied for the conceptual design of the machine:

EN 12999, EN ISO 12100, EN ISO 4413, EN ISO 13857, EN ISO 4254-1, EN 60204-1

Iisalmi
(Place)

19.10.2016
(date)

Sami Jerkku

PRODUCT WARRANTY

Farmi provides a 12-months warranty on all Farmi products.

Register on our home page (www.farmiforest.fi) under FeedBack ("Product Registration" form) within 30 days after the receipt of the product to get full product warranty and additional information on your product. If it is not possible for you to register via internet, please register as follows: Complete the registration form on the last pages of this manual and return it to us within 30 days after the receipt of the product.

GENERAL SAFETY INSTRUCTIONS

These safety instructions are meant for the owners of FARMl equipment, as well as those who operate, service or repair it.

The instructions help with:

- using the machine safely, appropriately and effectively.
- identifying, avoiding and preventing potentially dangerous situations.

The manufacturer supplies an instruction manual, which must always be available at the place of operation of the machine. Each user must read the safety, maintenance and operating instructions before operating the machine, and comply with these instructions at all times.



Ensure that every operator of the machine is familiar with the content of the instruction manual and situation-specific safety instructions, and has been suitably trained before operating the machine.

The machine complies with technical requirements and applicable safety regulations. However, incorrect use, maintenance or repair of the machine may cause risks.

In addition to the instruction manual, remember to comply with regulations of the local occupational health and safety authorities, and with your country's laws and decrees.

The manufacturer is not liable for damages caused by:

- incorrect, negligent or inappropriate use of the product.
- non-original spare parts.
- normal wear and tear.
- misuse caused by an untrained person's improper actions.
- alterations made without the manufacturer's permission.



Written authorization must be requested from the manufacturer for any alterations to the machine.

STARTING

- Familiarize yourself thoroughly with the use, operation and controls of the machine and its equipment before starting.
- Familiarize yourself with the capacities and limitations of the machine and its equipment.
- Do not use the machine unless you are completely familiar with its operation.
- Be aware of the machine's danger zones.
- During operation, prevent bystanders from entering the danger zone.
- Ensure that each operator has the necessary safety equipment, such as a helmet, safety goggles, work safety boots and suitable protective clothing.
- Never wear loose clothing around moving parts. Protect long hair!
- Ensure that work is carried out according to the stipulations of applicable occupational health and safety legislation.
- Before starting up or using the machine, ensure that it cannot cause a risk to other people or property.
- Perform a safety check on the machine before every use. If you observe any faults or deficiencies, repair the machine immediately.
- Before operating the machine, ensure that there are no foreign articles in it.
- Place the machine on a hard, level surface for operation. In the winter avoid working in slippery areas.
- Before mounting and using the machine, check the PTO drive shaft for correct condition and attachment.
- Never use a faulty or deficient machine.

TRANSPORT

- Before driving with the machine, ensure the safe mounting of the machine. Make sure that the journals are seating correctly and that the pins are tight. Check the tension of the lower link stabilizers.
- Before driving with the machine, make sure that the required lamps and reflectors as well as the slow moving vehicle sign are attached correctly. Moreover, the lamps should be checked for correct functioning.
- Before driving with the attached machine, make sure that the hydraulic unit of the machine is depressurized (unless otherwise instructed in the operating instructions).
- When driving on public roads, always observe the valid traffic regulations. The travel speed must be adapted to the specific conditions.
- When driving, please take into consideration the additional mass resulting from the machine's weight. It may affect the reactions, the steerability and the braking function of the tractor.
- Please note that the machine rear sways when turning.
- Pay attention to the machine's height near bridges or other height restricting objects.
- When backing off, the machine may obstruct the rear view. Exercise extreme caution. If necessary, ask a flagman to help you; he can indicate the required distances.
- It is prohibited for other people to ride on the machine.

- Never insert any body part into the machine with the engine running.
- If any faults arise that may jeopardize occupational safety, turn off the machine.
- During operation, the machine's operator is responsible for safety in the whole work area. Work may not be carried out in the presence of any factors that jeopardize occupational safety.
- Exercise extreme caution when hitching / unhitching the machine from a tractor/trailer.



The machine's operator must have constant, unobstructed visibility of the work area. If this is not possible, the operator must work with an assistant.

- Look out for moving parts when the machine is in operation.
- Secure the machine against unauthorized and accidental operation (e.g. moving when parked) whenever it is left unattended.
- Never leave the machine running unattended.
- Avoid causing fast, stroke-like loading.
- Never exceed the given operating values.
- All safety and warning signs on and in the machine must be legible and intact.
- The machine may not be operated by persons who are unwell or under the influence of drugs or alcohol.

OPERATION



Many occupational accidents take place in abnormal circumstances. Therefore it is important to take into account all the possible circumstances that may arise during operation of the machine.

- Depending on the machine's type, it will have diverse safety devices and protectors. These are meant to protect the machine and its operator, and they must never be removed or altered. Never start up or use the machine without all the safety devices and protectors in place. Also check the universal joint's safety equipment and joints.

MAINTENANCE

- The machine may only be serviced and repaired by professionals.
- Electrical and hydraulic faults may only be repaired by authorized professionals.
- In cases requiring welding, contact the manufacturer.
- Turn off the tractor engine and disconnect the universal joint before beginning service or maintenance actions.
- Before any maintenance work, turn the main power switch of the tractor to OFF.
- Ensure that there is no pressure in the hydraulic system.
- Take out the key from the tractor's ignition for the duration of the servicing or maintenance. Check that the power is off from the machine you are working on.

- When servicing the machine, place it on a level surface and ensure that it cannot be moved.
- Observe the service intervals and annual safety inspections.
- All spare parts and equipment must fulfill the manufacturer's requirements. This can be guaranteed by using original parts.
- Put all safety devices back into place immediately once servicing or maintenance is complete.



When lifting the machine, check that the lifting/hoisting equipment is in perfect working order. Check the weight of the machine before lifting it. Choose lifting trajectories so that they do not cause any danger.

Many countries have specific legislation on lifting, hoisting cables and hoists. Always comply with local safety regulations.

OILS AND LUBRICATION

- Always use the oil types recommended by the manufacturer. Other types of oil may cause faults or improper operation of the equipment, which could lead to serious damage to people or property.
- Never mix different liquids or oils.
- Always follow the manufacturer's lubrication instructions.
- Use control equipment carefully until the hydraulic oil has had time to reach its operating temperature.

SAFETY INSTRUCTIONS FOR HYDRAULIC CIRCUITS

1. Work on hydraulic equipment may only be carried out by professional hydraulic engineers.
2. Be cautious when using the equipment in cold conditions.
3. Check the machine for leaks. Do not use the machine if there is a leak from any system. Check all hydraulic hoses – particularly those which are bent during use – and replace any that are in poor condition or have leaks. Ensure that all joints are tight and that the lines are not damaged. Check that all protective caps and filler caps are closed properly. Check the hose sheathing for damage.
4. Check that all hose connectors, lengths and qualities comply with applicable requirements. When replacing or repairing hoses, use original parts or hoses and connectors recommended by the manufacturer. Check particularly that the pressure classes of the hoses and connectors are suitable to the operating pressure levels.
5. Check that all safety devices such as pressure relief valves, etc., are in place and work properly. Familiarize yourself with their use. Safety systems may never be bypassed.
6. Check the main hydraulic parts daily, and always after a fault. Replace any damaged parts immediately.
7. If a component is damaged, clean it before repairing it. Do not use solvents when cleaning parts.
8. Do not attempt to carry out repairs that you are not fully familiar with.
9. Never carry out repairs of the hydraulic circuit when the system is pressurized. When pressurized, the oil spray can penetrate the skin and cause mortal danger.
10. Never work below a device or component that is only being held up by hydraulics. Use separate supports when carrying out maintenance or repairs. Do not disconnect cylinders or their valves until the machine is well supported.
11. Most hydraulic oils do not evaporate easily. Risk factors include hot oil, spills and oil mist (pressurized).
12. If oil gets into your eyes, rinse with plenty of water and contact a doctor.
13. Avoid prolonged or repeated contact with your skin.
14. If sprays or contact with the skin cannot be avoided, use protective gloves, goggles and clothing as necessary. Do not use oily clothing.
15. Avoid discharging hydraulic oil into the

environment, as it can pollute waterways and the groundwater. If biodegradable oil is to be used, please contact the manufacturer beforehand and have the suitability of your equipment for the operation with biodegradable oil confirmed by him before such oil is used.

16. Store the oil in sealed containers provided by the manufacturer. Try to transfer the oil directly from its container into the tank.
17. If the oil must be passed through other containers, ensure that they are completely clean. Caps, funnels, sieves and filling holes must also be clean.
18. Never store oil outdoors, as water could condense in it.
19. Always dispose of oil in a suitable container, never into the environment!

CR40

SAFETY INSTRUCTIONS FOR LOADERS

- Ensure the machine is properly supported during storage.
- Council of State Decision 856/1998 requires that loading crane operators be at least 18 years of age and have received sufficient instruction in its operation. This applies in Finland.
- Before starting the machine, ensure that there are no bystanders within a radius of 20 meters.
- During operation, the vehicle must be positioned on sufficiently solid ground, in a properly stable position. The support legs must be used in all circumstances.
- Always put on the parking brake during loading.
- Do not exceed the given load values.
- Never stand beneath a hanging load.
- Do not leave booms in raised position unattended!
- The loader must not be used for lifting people.
- When lifting, note that the booms sag slowly.
- When working in the proximity of live wires, always adhere to the given safety distances (cf. table).
- Take particular care when lifting heavy loads and turning the loader to the side.
- Never use the loader for towing.
- Do not run the machine's movements to their extremes at full speed.
- If the vehicle assembly falls over, do not jump out of the vehicle.
- If the booms sag down under excess loading, use the shifting boom to shift the load closer to the column. Do not open the grapple.
- If the machine comes into contact with a power line, do the following:
 - Call for assistance immediately and ensure that no one enters the danger zone.
 - If you are outside the machine, do not touch any part of the machine.
 - If you are inside the machine, leave it by JUMPING OUT. When you jump, make sure both feet touch the ground at the same time. Do not touch the vehicle or the ground with your hands after jumping out. Move at least 20 meters away from the vehicle by hopping on two feet.

Voltage rating, kV	Minimum distance, m		
	Overhead line		Pendant line
	below	on side	
<1	2	2	0,5
1-45	2	3	1,5
110	3	5	-
220	4	5	-
400	5	5	-



The noise level from the engine should not exceed 70 dB. Check the engine noise and wear ear protection if it exceeds 70 dB.

CR40

STICKERS AND PLATES

The following plates and labels must be correctly attached to the machine. Missing safety plates / labels must be replaced immediately.

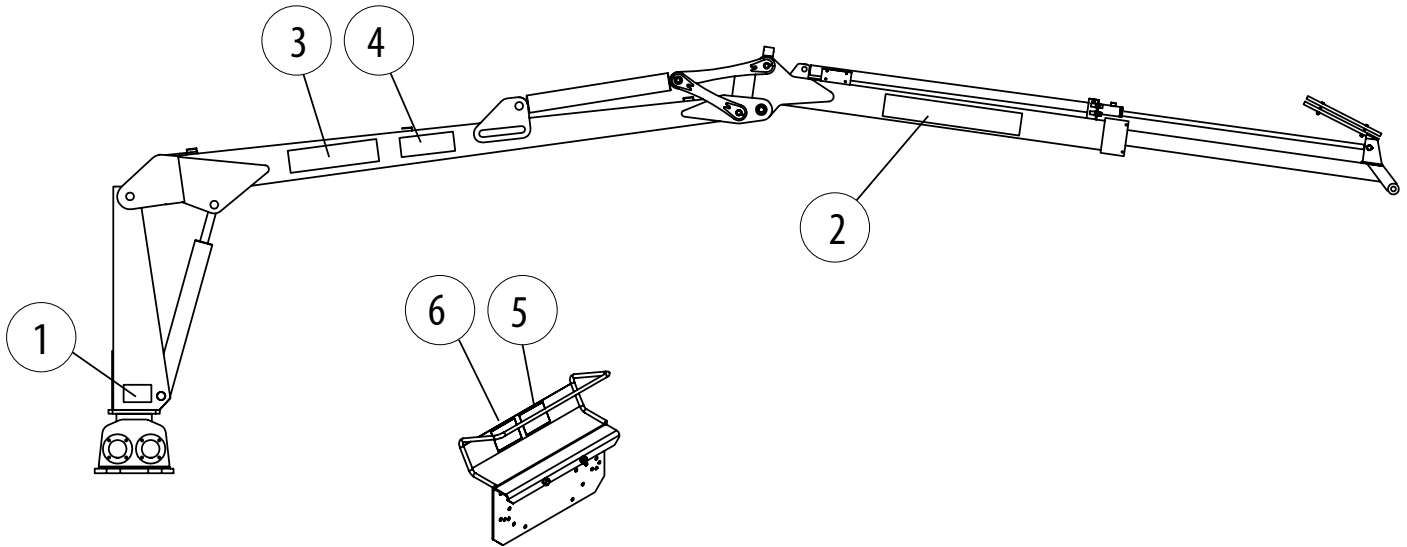

Farmi Forest Corporation		CE
Ahmolantie 6 FIN-74510 IISALMI FINLAND		
TYPE	FORESTRY CRANE	200002497
MODEL	CR40 SMART	
SERIAL NO.		
YEAR OF MANUFACTURE	20	
WEIGHT CRANE	600 kg	
MAX. HYDR. PRESSURE	180 bar	
OIL FLOW NEEDED	25-50 l/min	

1. Machine plate CR40 (200002497)



4. Sticker CR40 (200002517)

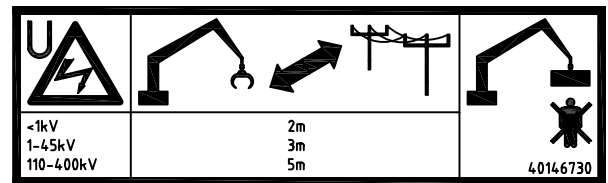

5. Minimum distance (40146730)



2. Danger area 20 m (40146720)



3. Farmi Smart (20002509)

	74.0	585	505	420	355	kg
CR40 SMART	3.0	4.0	5.0	6.0	6.7	7.0 m
CR46 SMART	955	760	615	515		425 kg

6. Lifting capacity (200002556)

CR40

TECHNICAL DATA	CR40
Gross lifting torque, kNm	39
Net lifting torque, kNm	26
Max. reach, m	6,7
Weight without equipment, kg	705
4 m	445
6,7 m	
Slewing torque, kNm	11,6
Weight with equipment, kg	735
Hydraulic support legs, weight, kg	295
Recommended pump capacity, l/min	30-60
Working pressure, bar	180
Directional control valve, standard (accessory)	On/Off (HPC)
Hydraulic support legs with 3-point linkage	standard

CR40

MAIN COMPONENTS

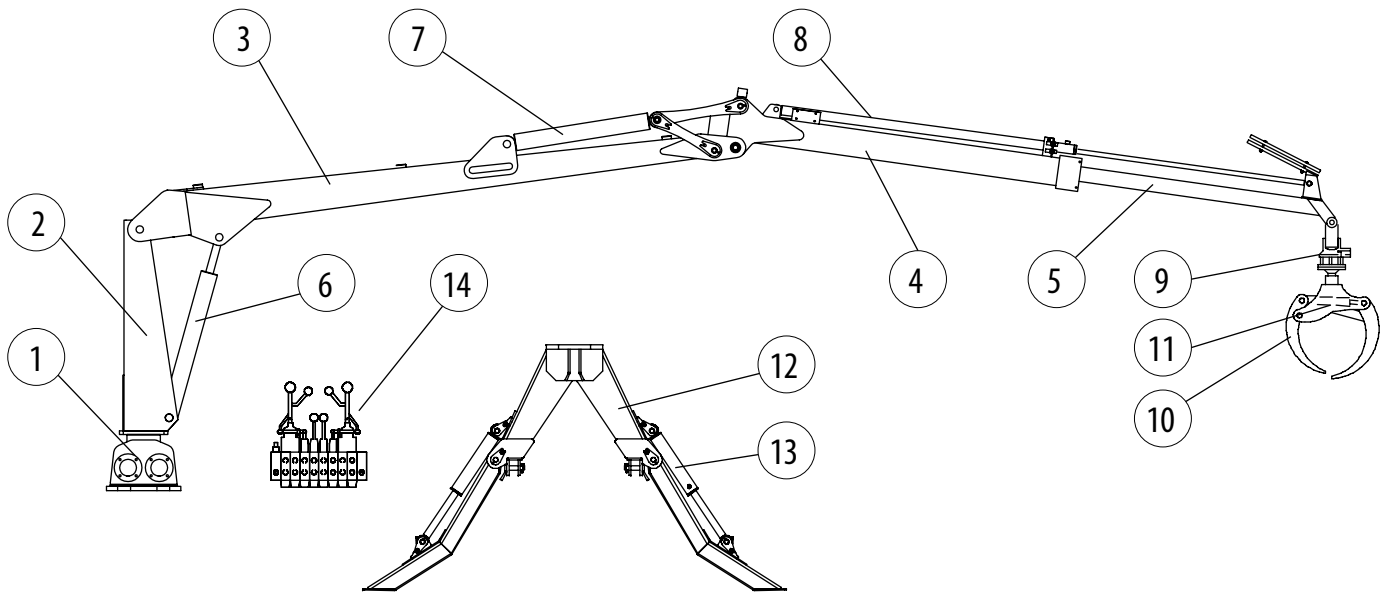

1. Slewing device
2. Column
3. Lifting arm
4. Folding arm
5. Extension boom
6. Lifting cylinder
7. Folding cylinder

8. Extension boom
9. Rotator + pendant
10. Grapple
11. Grapple cylinder
12. Mounting rack + hydraulic support legs
13. Support leg cylinder
14. Directional control valve

ASSEMBLY AND MOUNTING



Read these instructions before starting any assembly or mounting work. Improper mounting work can cause hazards during use of the crane.

Mounting carried out in a manner other than that specified in this manual can expose the user to danger and will void the manufacturer's guarantee.

Check the stability of the crane-vehicle assembly by performing the necessary calculations. See Section "Determining the stability".

The mounting must be performed by the manufacturer or a service center or person authorized by the manufacturer.

The strength class of the mounting bolts is 8.8. Use self-locking nuts, e.g., DIN985.

Tightening torque 420 Nm!



Retighten the bolts after the test run and the first day of use.

INSTALLATION INSPECTION

Decisions 354/83 and 530/83 made by the Finnish Council of State stipulate that an installation inspection must be performed for each crane-vehicle assembly before use. An inspection form can be found in this manual.

The person performing the inspection must be familiar with the crane's construction and operation.

MOUNTING THE MULTI- AND DOUBLE-ACTING VALVES



The valve must be positioned or covered so that the levers cannot be used inadvertently.

Install the valve using the included bracket at the desired location, paying attention to the direction of the hoses and movement during loading and transferring so that there is no risk of abrasion or clamping. The label indicating the safe distance from live conductors must be clearly visible during operation.



Hoses in the operator's cabin must be protected so that the user is not endangered by oil jets in the event of breakage.

The levers in the multi-lever valve can be moved to different positions if necessary. Detach the levers from the valve before moving them.

CONNECTION TO THE HYDRAULIC SYSTEM

Before connecting the crane to the tractor's hydraulic system, make sure that the oils are compatible.

The crane has been tested using 10W/30 oil that meets the API SE, CD, and API GL-4 requirements.

We recommend connecting the pressure hose to the single-acting hydraulic outlet and the return hose to the tank via the return filter. The filter's intended flow rate is 80 l/min and the filtering density 25 µm abs.

The crane can also be connected to the double-acting hydraulics outlet. If this is done, make sure that the lever of the double-acting valve controlling the flow is in the right position so that the pressure is directed to the pressure connection of the crane's control valve. Check the operation of the double-acting outlet in the vehicle's operating manual.

COMMISSIONING



Before using the crane, familiarize yourself with the operating and safety instructions.

INSPECTIONS BEFORE TESTING

Do not pressurize the hydraulic system before connecting the control valve's 1/2" quick couplings to the vehicle's hydraulic system.

Connect the pressure hose (P) to the valve as indicated by the arrow and the return hose (T) to the vehicle as indicated by the arrow.



Do not pressurize the control valve's return line (T) – this could cause the valve to break. Ensure that the 1/2" quick coupling are locked.

TESTING

1. Ensure that the control valve's control levers are in the middle position.
2. Connect the oil flow to the crane. Let oil flow through the valve for a while.
3. Lower the support legs.
4. Carefully drive the crane movements one by one to their extreme positions and repeat this until the movements are smooth.
5. After testing the crane, inspect the joints and repair any leaks.
6. Check the mounting bolts of the crane and the fitting stand, and tighten them if necessary.
7. Check the hydraulic oil level, and top up the oil if necessary.



Be careful when bleeding air from the system. If you drive a cylinder to its extreme position at full force, the air pressure in the cylinder will damage the seals.

The person testing the crane must be qualified to use it.

1. Read the installation inspection report. If no installation inspection has been performed, do not use the crane.
2. Ensure that the control valve's pressure line (P) has been connected properly and that the return (T) is unobstructed.
3. Check the hydraulic oil level.
4. Familiarize yourself with the control valve's functions.
5. Ensure that the hoses can move freely. Remove any transport supports and ties.
6. Ensure that there are no people or obstacles in the operating area. The danger zone is 20 m.
7. The crane must be tested on a level, firm base.



Be extremely careful when there is air in the cylinders.

PRACTICE RUNS

- Drive through every movement with an unloaded crane, paying attention to the positions in which the crane can hit obstacles.
- Move the control levers smoothly and steadily, avoiding quick and jerky movements.
- Learn to use several functions simultaneously. This enables smooth, precise operation.
- Start off at a low engine speed in order to avoid sudden movements.
- When you have become accustomed to the crane's movements, choose the appropriate engine speed so that operation is efficient but you still have the movements under control.

The lowest recommended operating temperature for the crane is -25°C .

Note that the hydraulic seals, hoses, and steel structures are prone to damage at low temperatures. When starting work at cold temperatures, first let the oil flow freely through the valve for a couple of minutes.

The maximum operating temperature for hydraulic oil is $+75^{\circ}\text{C}$.



Use the support legs only to provide additional support for the vehicle.

When working on an inclined surface, do not load the crane with the full lifting torque, and be extremely careful.

When loading from uphill, note that the slewing movement may not be able to support the load but the pressure relief valves can be overloaded and the load can move down, causing a danger of the crane falling over.



Never move the boom to its extreme position at full speed!



Be careful when working near electric cables. Observe the safe distances.

When transferring the crane, support it against the trailer body or load.

DETACHING THE CRANE

Ensure that the ground under the crane is sufficiently hard and level.

Ensure that there are no extra people around and that no danger will be caused to others where the crane is to be stored. Pay special attention to the storage location of the control valve, ensuring that, e.g., it is out of the reach of children.



Always switch the pump off before removing the quick coupling between the crane and the vehicle.



When detaching the crane from the vehicle, make sure that there are no people in the immediate vicinity.

1. Lower the support legs to the desired height.
2. Lower the booms as shown in Fig. 1.
3. Lower the crane using a hoist.
4. Make sure that the crane cannot lean over. Fig. 1.
5. Detach the crane from the vehicle.
6. Detach and cover the control valve's quick couplings.

STORAGE INSTRUCTIONS

1. Clean the crane and, if necessary, touch up any points where paint has peeled off.
2. Lubricate the crane thoroughly (see Lubricating Instructions).
3. Release the pressure from the cylinders.
4. Protect the cylinder piston rods and exposed parts of the control valve with grease.
5. Store the crane in a sheltered area, away from direct contact with the ground.
6. When you start using the crane again, remove the protective grease from the cylinder piston rods and the control valve.

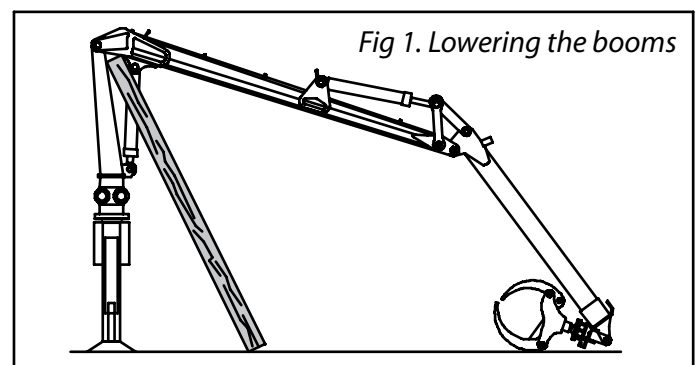

HYDRAULICS

CONNECTION TO THE CLOSED CENTER SYSTEM, ON / OFF, 60 l

1. Replace the R1/2" plug on the T fitting by a R1/2" double nipple. Connect the tank hose here.
2. Plug this hole for the tank hose with R1/4" and R1/2" plugs.
3. Tighten the main relief valve by $\frac{3}{4}$ turn so that its pressure is at least 5-10 bar higher than that of the tractor

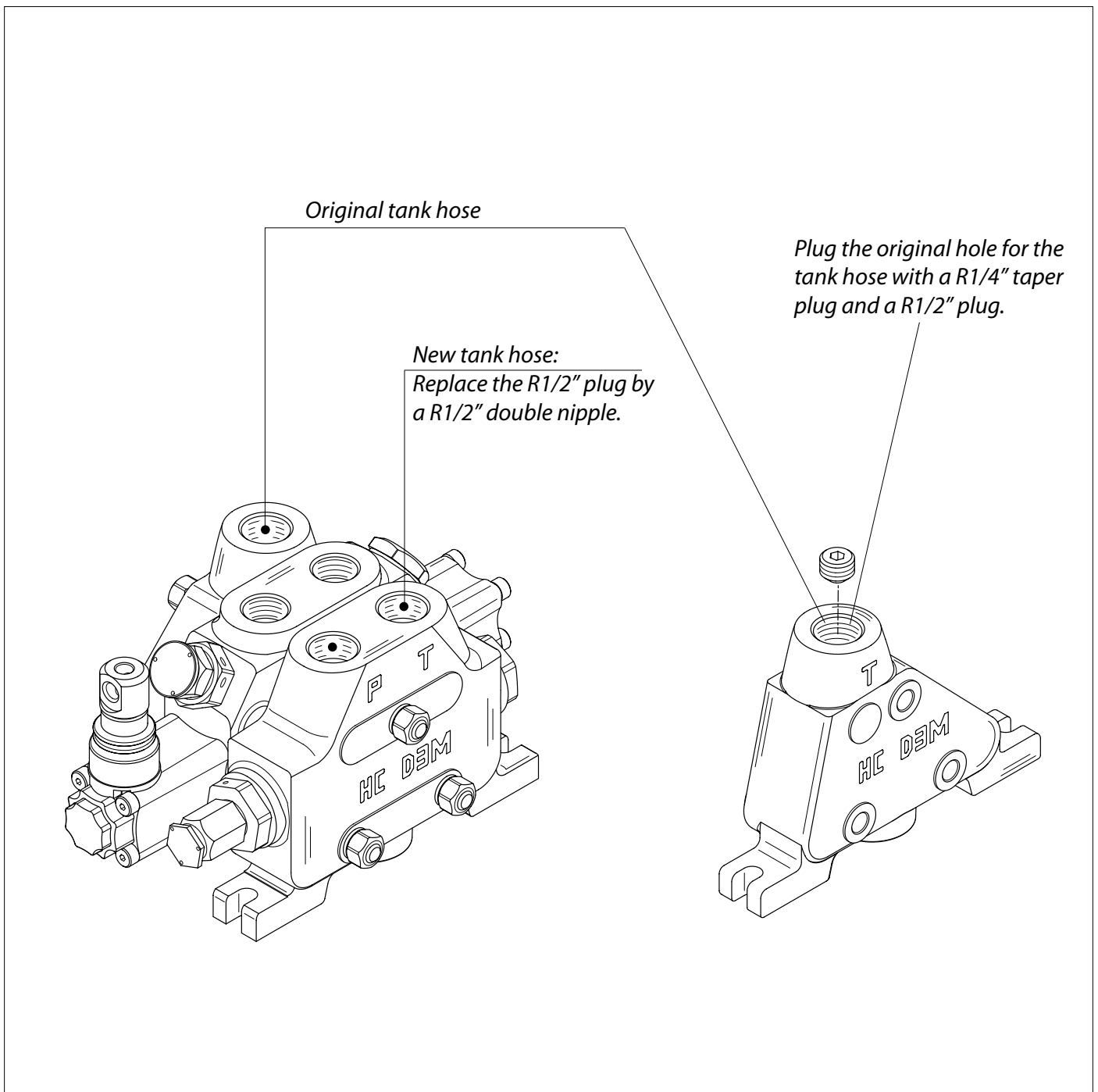
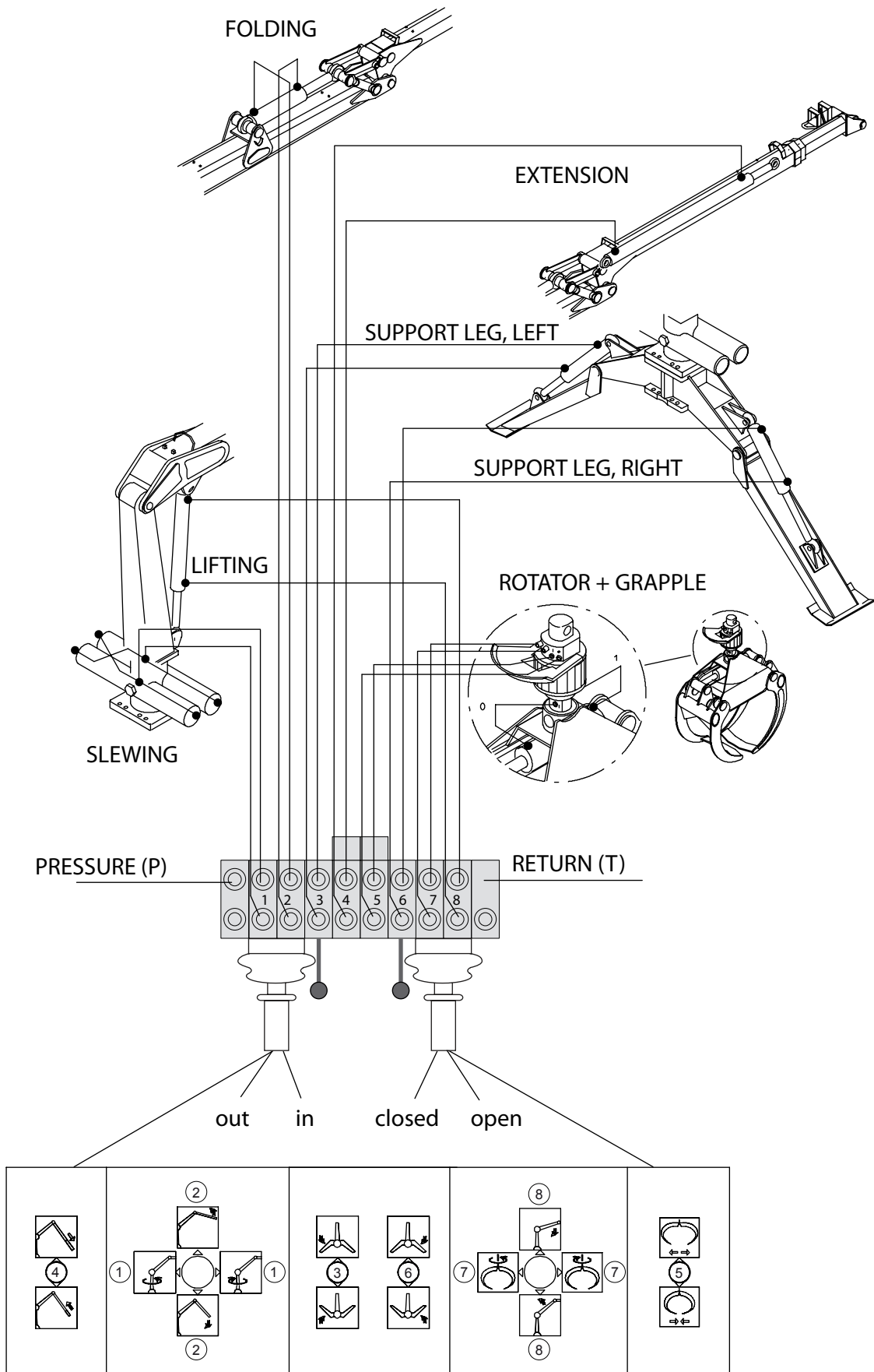

Fig 4. Modifying the valve for closed center system

CR40

CONNECTING THE ON/OFF VALVE



PRESSURE RELIEF VALVES

FUNCTION	ON/OFF VALVE		
	MAIN PRESSURE RELIEF VALVE 180 bar		
	BLOCK	PRESSURE RELIEF VALVE (bar)	
pin locking		lever	
SLEWING	1	185	185
LIFTING	8	185	-
FOLDING	2	160	185
ROTATOR	7	-	-
GRAPPLE	5	-	-
EXTENSION	4	-	90
SUPPORT LEG, LEFT.	3	-	-
SUPPORT LEG, RIGHT	6	-	-

CR40

TESTING THE STABILITY

The formulas and examples included in these instructions are based on the SFS 4677 standard.

During the test, the vehicle is in normal working condition without load, tilted 5° to the side. The ground must withstand the maximum load applied by the wheels or the other points of support.

- The test is performed at the maximum reach with 10% overload. All normal crane functions are performed, but cautiously. The vehicle's 5° inclination is achieved by putting a suitable riser under one of the rear wheels. Its height can be calculated as follows:

h = riser height needed

z = vehicle width from wheel center to wheel center

$$h = 0.087 \times z$$

Example:

$$z = 120 \text{ cm}$$

$$h = 0.0887 \times 120 \text{ cm} = 15 \text{ cm}$$

- The vehicle is considered stable if no more than one point of support rises off the ground during the test. Increased stability when loading it from the side can be achieved by widening the track and/or adding rear axle load by using, for example, wheel weights.

DETERMINING THE STAND-STABILITY BY CALCULATION

The crane is considered stable when the stability ratio "n" calculated from formula below is equal or larger than 1.

A = Normal distance from cranes turning center to overturning edge.

B = Normal distance from booms end (load) to overturning edge.

C = Distance from vehicles rear axles center and overturning edge.

E = Normal distance from booms point of support to overturning edge.

G = Maximum load at distance $A + B$

N = Cranes weight without booms

P = Booms weight (centroid)

M_2 = Rear axle weight without load

n = Stability factor

You can use the example for calculating the stand stability for any tractor by measuring "K" and "H" from the tractor. With these measures you can calculate "C". See the tractors manual for rear axle weight M_2 , "n" value must be more than 1.

EXAMPLE 1			
tractor Valtra T190 + FT9 + CR40			
Formula	$n =$	$\frac{N \times A + M_2 \times C}{G \times B + P \times E}$	
$N = 530 \text{ kg}$	$B = 490 \text{ cm}$	$C = 120 \text{ cm}$	
$A = 180 \text{ cm}$	$P = 340 \text{ kg}$	$M_2 = 1250 \text{ kg}$	
$G = 430 \text{ kg}$	$E = 70 \text{ cm}$		
$n =$	$\frac{530 \times 180 + 1250 \times 120}{430 \times 490 + 340 \times 70}$		$= 1,05$

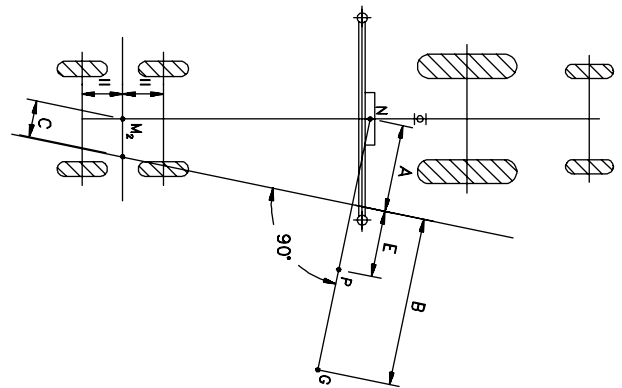

EXAMPLE 2			
tractor Valtra T190 + CR40			
Formula	$n =$	$\frac{N \times A + M_2 \times C}{G \times B + P \times E}$	
$N = 530 \text{ kg}$	$B = 530 \text{ cm}$	$C = 100 \text{ cm}$	
$A = 140 \text{ cm}$	$P = 340 \text{ kg}$	$M_2 = 2190 \text{ kg}$	
$G = 430 \text{ kg}$	$E = 110 \text{ cm}$		
$n =$	$\frac{530 \times 140 + 2190 \times 100}{430 \times 530 + 340 \times 110}$		$= 1,11$

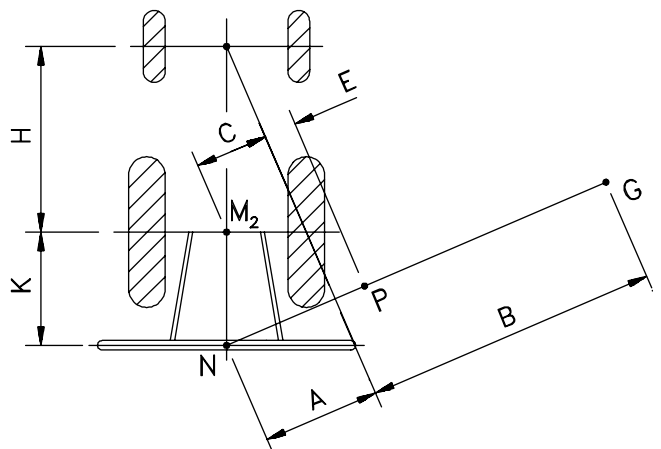

Formula	$C =$	$\frac{H \times A}{K + H}$
---------	-------	----------------------------

CR40

MAINTENANCE

OBJECT	ACTION		
	Maintenance interval, working hours		
	8 h, or after working shift	50 h, or after working week	After 250 working hours or once a year
General	Check cylinders and leakages in hoses	Check pins and lockings Check fastening bolts	Check the condition of primary structures
Slewing device	Lubricate slide bearings Check oil level		Tighten the fastening bolts Adjust racks support bearings
Booms	Grease slide bearings Lubricate extension's upper and lower surfaces		Check sliding bearings and sliding plates
Cylinders	Lubricate swing bearings Check condition of piston rod and piston rod oil ring		Sylintereiden laakereiden tarkistaminen
Grapple	Grease slide bearings		Check grapples fixing to rotator
Support legs, mounting base	Grease slide bearings		Check hydraulic cylinders bearings

MAINTENANCE

- Maintenance work must be carried out regularly to ensure safe and trouble-free operation.
- Always use the appropriate tools.
- Determine the location of the defect.
- Keep the disassembled sections, removed parts, and the repair area protected from dirt.
- Clean the parts using kerosene, never fuel oil.
- Valve adjustments and repairs are to be performed by dedicated service personnel.

REPLACING BEARINGS

- When installing bearing sleeves, use an appropriate drift.
- Make sure that the new bearing's grease hole meets the nipple.
- If the bearings have grease pockets, fill these with Vaseline.

LUBRICATION

Inject new grease so that old grease is squeezed out. Wipe off excess grease.

SLEWING DEVICE

Lubricate the slewing device in accordance with the lubrication instructions.

BOOMS

Keep the axial clearance in the joints as small as possible. Do not over-tighten.

Apply grease on the upper and under side of the extension. The sliding plates are not adjustable. Replace worn out sliding plates by new ones. The sliding plates must be replaced by new ones before the booms rub against each other.

PRESSURE MEASUREMENT

Always make the adjustments with the manometer in place.

- The main pressure is measured from the measuring point in the control valve's inlet section.
- Adjustments and inspections for each movement:
 - Set the main pressure relief valve to 5 bar above the value set for the protective valve.
 - Perform the movement, and check and adjust the pressure if necessary.
 - Finish by adjusting the main pressure to the set value.
- Pressure measurements are to be performed at the normal operating temperature and at the normal flow rate.
- The free flow pressure can be read from the manometer when the flow of oil is directed through the valve.

REPAIR WELDING

If welding is required for modifying or repairing the crane, note the following:

- The welder must be qualified: welding grade 3. There must be no root defects.
- Remove paint and any oil from the location to be welded.
- Connect the ground terminal directly to the piece to be welded – there must be no joints in between.
- Use OK 48.00 or equivalent electrodes. The electrodes must be dry.
- Improperly welded structures can get fractured.

CR40

TROUBLE SHOOTING

TROUBLE	POSSIBLE CAUSE	REMEDY
CRANES WORKING MOVEMENTS SLOW	PUMP IS TOO SLOW	CHECK PUMPS ROTATING SPEED
	FAULTY PUMP	CHANGE OR GET THE PUMP FIXED
	LEAKS OR OBSTRUCTIONS IN OIL LINES	INSPECT OIL LINES
	OIL TOO THICK	CHANGE TO A THINNER (CORRECT) OIL GRADE
CRANES DESCENDING MOVEMENTS SLOW	OBSTRUCTIONS IN THE OIL LINES	CHECK THE LINES AND THE CHOKES
	CLOGGED-UP (RETURN) FILTER	CLEAN OR RENEW FILTER
	OIL TOO THICK	CHANGE TO A THINNER (CORRECT) OIL GRADE
CRANES MOVEMENTS TOO FAST	ROTATION SPEED TOO HIGH OR PUMP TOO BIG	CHOOSE A CORRECT SPEED OF ROTATION AND CORRECT PUMP SIZE
	INCORRECT OPERATION	LEARN TO OPEN THE CONTROL VALVE TO A SUITABLE DEGREE
CRANES WORKING MOVEMENTS POWERLESS	NOT ENOUGH OIL	ADD OIL (AIR BLEEDING)
	FAULTY PUMP	CHANGE OR GET THE PUMP FIXED
	FAULTY RELIEF VALVE OR SHOCK VALVES	CHANGE THE RELIEF VALVE OR SHOCK VALVES
	FAULTY CONTROL VALVE	CHANGE OR GET THE VALVE FIXED
	FAULTY CYLINDERS OR SEALS	CHECK THE CYLINDERS AND CHANGE THE SEALS
CRANE MOVEMENTS ARE JERKY	AIR IN HYDRAULIC SYSTEM	CHECK OIL LEVEL, BLEED AIR FROM SYSTEM
	NOT ENOUGH OIL	CHECK THERE ARE NO OBSTRUCTIONS OR LEAKS ON THE INLET SIDE, ADD OIL
	FAULTY PUMP	CHECK THE PUMP AND GET IT FIXED
BOOMS DESCEND BY THEMSELVES	FAULTY CONTROL VALVE	INSPECT THE CONTROL VALVE AND GET IT FIXED
	FAULTY CYLINDERS OR HOSES FAULTY SHOCK VALVE	FIX THE LEAKAGE POINT. CHECK CYLINDERS AND SEALS, CHECK, CLEAN, ADJUST
CONTROL VALVE'S SPINDLES STICKING	VALVE'S FIXING SCREWS TOO TIGHT	CHECK SCREWS TIGHTENING TORQUE 50 Nm (5 kPm)
	VALVE NOT ON LEVEL MOUNTING BASE	MOUNT THE VALVE ON A LEVEL BASE
	VALVE'S TIE BOLTS TOO TIGHT, FAULTY SPINDLE	CHECK SCREWS TIGHTENING TORQUE 27,5 Nm (2,75 kPm), CHANGE A NEW BLOCK WITH SPINDLES

CR40

LUBRICATION

Using the appropriate hydraulic oils and lubricants is essential for the trouble-free operation of the machine.

CHANGING THE OIL

Change the oil according to the vehicle's maintenance recommendations.

The crane has been filled with ISO WG46 oil at the factory.

If the oil temperature does not exceed 70°C in the summer, winter oil can be used all year round.

When changing oil, make sure that the oil grade being used is compatible with the system and any oil remaining in it.

HYDRAULIC OIL REQUIREMENTS

The freezing point must be below -50°C.

The viscosity must not be lower than 1.5 E^o, +50oC for piston pumps and 2.5 E^o, + 50°C for gear pumps.

The hydraulic oil must contain the necessary additives for lubrication, rust protection, and defoaming.

Hydraulic oils intended for use in tractors are usually also suitable for use in hydraulic cranes.

OIL AND LUBRICANT GRADE TABLE

OIL MAKE	HYDRAULIC SYSTEM		GREASE NIPPLES
	-10°C ...+30°C	-25°C...-10°C	
BP	ENERGOL SHF 46	ENERGOL SHF 32,22	ENERGREASE LS-EP2, L21M
ESSO	UNIVIS N46	UNIVIS N 32,22	BEACON EP2, MULTIPURPOSE GR MOLY
MOBIL	DTE 16	DTE 15,13	MOBILUX EP 2 MOBIL GREASE MP, SPECIAL
SHELL	TELLUS OIL T46	TELLUS OIL T32,22	ALVANIA EP GREASE 2
TEBOIL	HYDRAULIC OIL 46	HYDRAULIC OIL 32, 33	SOLID 2/ summer SOLID 0/ winter
UNION / TEXACO	RANDO OIL HDZ 46	RANDO OIL HDZ 32, HYDRAULIC OIL HD 5W	MARFAK MULTI PURPOSE 2, MOLYTEX GREASE 2

LUBRICATING POINTS TABLE

Lubricating point	Qty	Action	Interval	Notes
Slewing device				
Bearings	1	Greasing	10 h	
Racks	4,5 l	Oil	Change the oil once a year.	GL-5, SAE 85W-90
Rack's support bearings	4,5 l	Oil	1000 h	GL-5, SAE 85W-90
Booms				
Articulation	6	Greasing	10 h	
Cylinder ends	4	Greasing	10 h	
Extensions surfaces	2	Lubrication	10 h	Apply grease to surfaces
Grapple				
Articulation	6	Greasing	10 h	
Cylinder ends	2	Greasing	10 h	
Support legs				
Articulation	2	Greasing	10 h	
Cylinder ends	4	Greasing	10 h	
Slide surfaces, 3-point frame		Greasing	50 h	

CR40

ANNUAL INSPECTION RECORD

F = faultless R = needs repair

ITEM UNDER INSPECTION	ANNUAL INSPECTION		
	F	R	NOTES
CLEANLINESS OF LIFTING BOOM			
WELDED JOINTS OF LIFTING BOOM			
WELDED JOINTS OF FOLDING BOOMS			
WELDED JOINTS OF COLUMN			
FASTENING OF ROTATOR			
STATE OF BRACKETS			
BACKLASH OF ROTATING DEVICE			
STATE OF SWIVEL AXIS BEARINGS			
STATE OF LIFTING BOOM BEARINGS			
STATE OF FOLDING BOOM BEARINGS			
STATE OF JOINT PINS			
LOCKING OF JOINT PINS			
STATE OF CONTROLS			
STATE OF CYLINDERS			
STATE OF CYLINDER GASKETS			
STATE OF PISTON RODS			
STATE OF HYDRAULIC HOSES			
STATE OF HYDRAULIC HOSE			
STATE OF HYDRAULIC CONNECTORS			
PROTECTION OF REGULATING VALVE LEVERS			
TIGHTNESS OF LOADER'S FASTENING			
OPERATION, MAINTENANCE AND INSPECTION MANUAL			
STATE OF SAFETY DISTANCE TABLE			
STATE OF LOAD SIGN			
STATE OF MACHINE PLATE			
HAS INSTALLATION INSPECTION BEEN CARRIED OUT?			
PRESSURE RELIEF VALVE _____ bar			
PROTECTION VALVES _____ bar			
STATE OF STRUCTURES AFTER MAX. ALLOWABLE TEST LOAD			
SAGGING OF BOOMS, MAX. RANGE OF 60 cm			
STATE OF SLIDE PLATES, MAX. GAP OF 8 mm			

Inspector:

Date and place:

Notes:

CR40

INSTALLATION INSPECTION RECORD

CRANE TYPE	FARMI	CHASSIS: model	
SERIAL NO.		make, model	
YEAR OF MANUFACTURE			
Load test according to SFS 4261	date:	performed by:	

F = faultless R = needs repair

ITEM UNDER INSPECTION	Notes	F	R
1. Before installation; 3-point lift			
state of lifting arm			
state of pusher arm			
locking of tractive resistance sensor			
gaskets and cleanness of hydraulic connections			
2. Before test drive			
check state of machine, load and operating plates			
stick minimum distance warning label e.g. to valve connector or rear window			
check sizes and locking of loader's mounting pins			
check that the hydraulic hoses are connected correctly			
check that fast couplings are securely in place			
check that valve shafts move smoothly			
check the amount of hydraulic oil in the tractor			
check valve table attachment			
check shielding of hoses in the cabin and shielding of levers			
check tightness of loader fastening screws (cf. installation manual)			
3. During test drive			
cylinder bleeding			
determining stand stability			
test use with allowable load (cf. loading table)			
loader/cabin at various hoist positions			
loader/cabin at various boom positions			
hose friction			
4. After test drive			
sagging of booms, max. range 15 cm/min			
check amount of oil with cylinders broken in			
oil leaks; tighten joints if necessary			

CR40

200000575 CR40

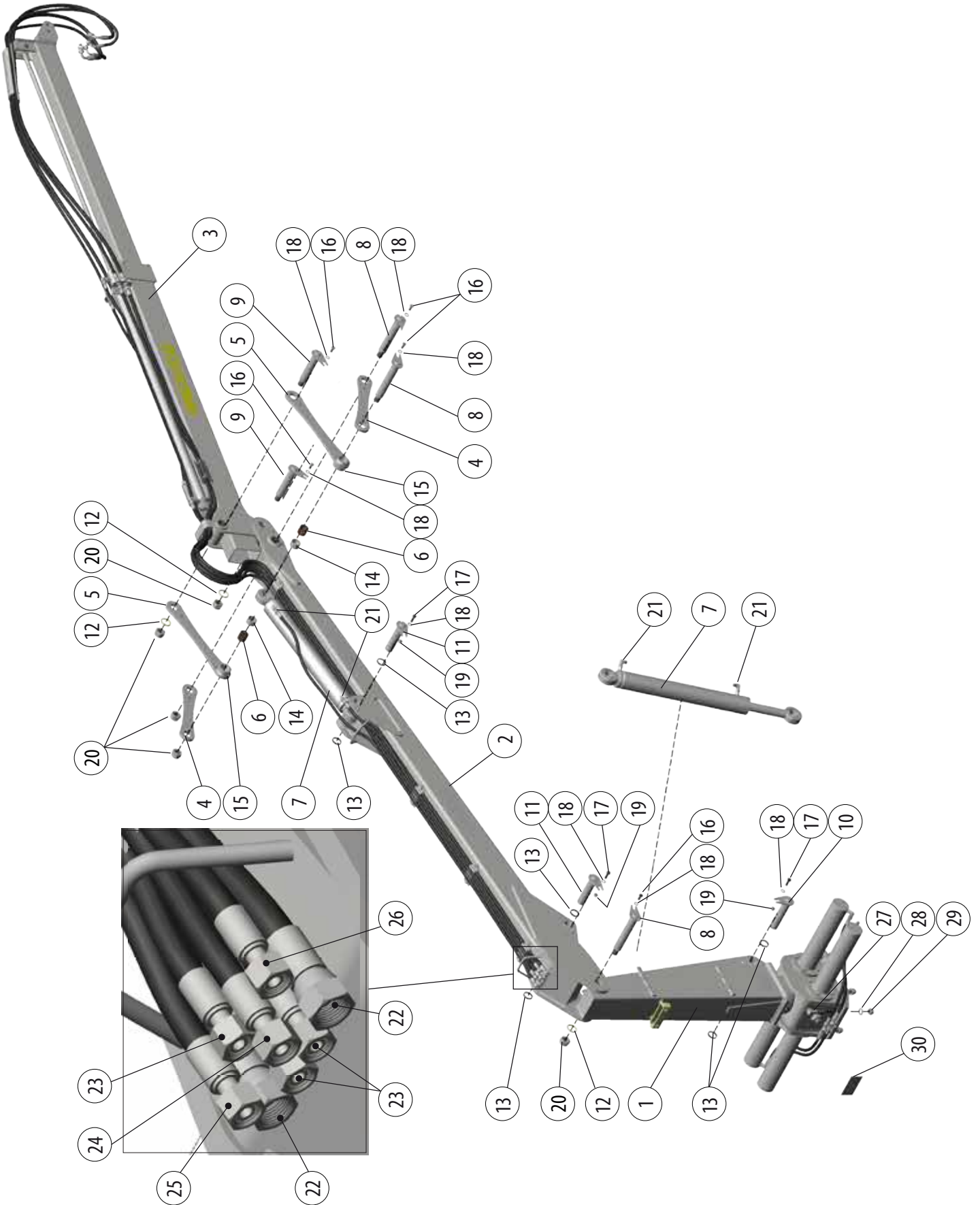

CR40

200000575 CR40

Part	Order no	Description	Remarks	Qty
1	200000535	Slewing device		1
2	200002521	Lifting boom		1
3	200000533	Folding boom		1
4	200000407	Joint arm		2
5	200000410	Joint arm		2
6	58204610	Plain bearing		2
7	58220330	Hydraulic cylinder	80/45-575	2
7.1	04080680	Seal kit		2
8	200000437	Joint pin	L=220,5 mm	3
9	200000436	Joint pin	L=175 mm	2
10	200000440	Cylinder pin	L=182 mm	1
11	200000443	Cylinder pin	L=165 mm	2
12	200000411	Washer	D55-6 mm	3
13	200000414	Stopper sleeve		6
14	200000415	Sleeve		2
15	52401023	Grease fitting	AM6	2
16	52062973	Hex screw	ST8.8ZN, M12X25, DIN933	5
17	52063591	Hex screw	ST8.8ZN, M12X35, DIN933	3
18	52200052	Washer	ST5.8ZN, M12, DIN125	8
19	52117124	Lock nut	ST8.8ZN, M12, DIN985	3
20	52117306	Lock nut	ST8.8ZN, M30, DIN985	5
21	52444820	Elbow fitting	R3/8, 90 °	4
22	200002623	Hose assembly	S1/2"S L=5,3 m	2
23	200002625	Hose assembly	S3/8", L=5,3 m	3
24	200002628	Hose assembly	S3/8" L=3,8 m	1
25	200002626	Hose assembly	S3/8", L=2,6 m	1
26	200002627	Hose assembly	S3/8", L=1,9 m	1
27	52062254	Hex screw	ST8.8ZN, M20X80, DIN931	8
28	52200086	Washer	ST5.8ZN, M20, DIN126	8
29	52117207	Lock nut	ST8.8ZN, M20, DIN985	8
30	200002556	Lifting capacity	sticker	1

CR40

200000535 SLEWING DEVICE AND COLUMN

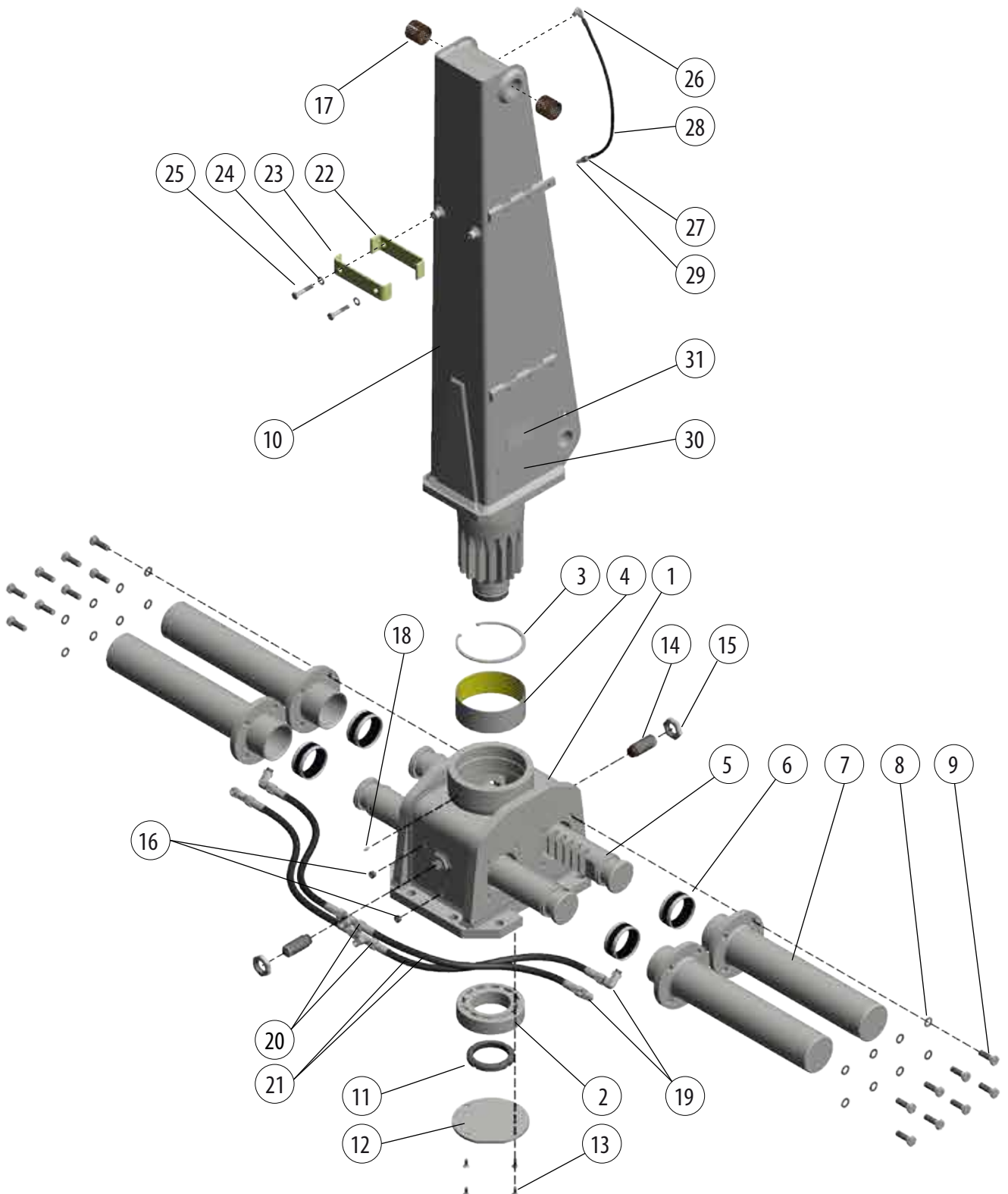

CR40

200000535 SLEWING DEVICE AND COLUMN

Part	Order no	Description	Remarks	Qty
1	200000564	Frame		1
2	54522354	Spherical roller bearing		1
3	52231545	Internal circlip	BLACK, 150x4, DIN472	1
4	54567029	Plain bearing		1
5	200000568	Gear rack		2
6	58217654	Piston seal		4
7	200000463	Cylinder tube		4
8	52211067	Spring washer	ZN, M14, DIN127	16
9	200001523	Hex screw	ST8.8ZN, M14X40, DIN933	16
10	200000536	Column		1
11	52118150	Axle nut	M80X2	1
12	200000570	Base plate		1
13	52090479	Hex socket cap screw	ST8.8ZN, M8X20, DIN7991	4
14	200000574	Support screw		2
15	52111119	Hex nut	ST8.8ZN, M30, DIN936	2
16	52081155	Plug	ST5.8ZN, R3/8, DIN906	2
17	58204610	Plain bearing		2
18	52401023	Grease fitting	AM6	1
19	52444820	Elbow fitting	R3/8, 90°	4
20	52443678	T-fitting	R3/8	2
21	56520067	Hose assembly	S3/8"S L=0,55 m	4
22	43463320	Pipe holder	6X40X184 mm	1
23	43463310	Pipe holder	6X40X188 mm	1
24	52200045	Washer	ST5.8ZN, M10, DIN125	2
25	52060266	Hex screw	ST8.8ZN, M10X50, DIN931	2
26	52422011	Angle coupling	R1/8	1
27	52421013	Straight thread connector	R1/8	1
28	56571040	Hose assembly	6SP 1/8 6SP L=0,5 TERMO	1
29	52401015	Grease fitting	AR1/8	1
30	200002556	Lifting capacity	sticker	1
31	200002497	Machine plate	sticker	1

200002521 LIFTING BOOM

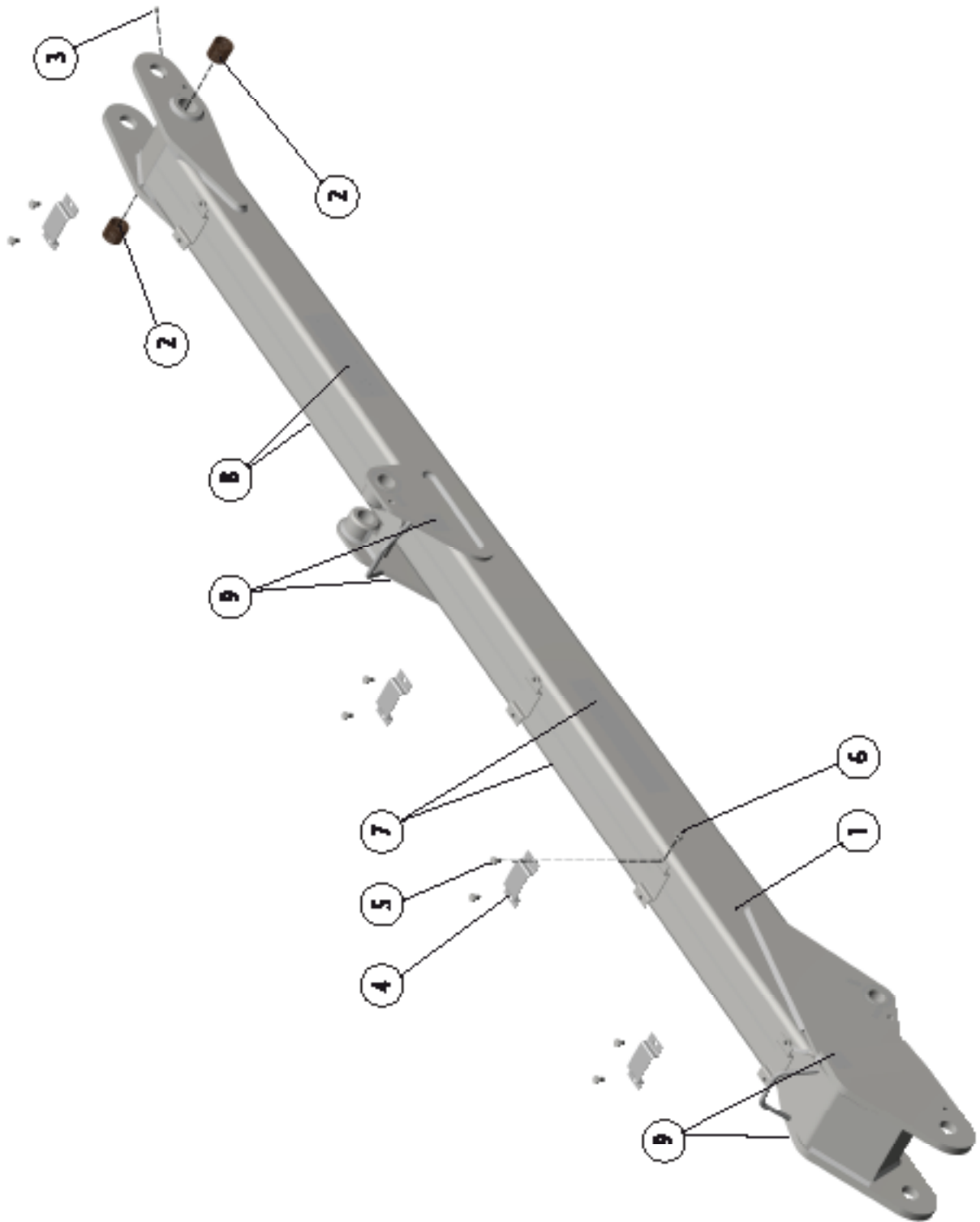

CR40

200002521 LIFTING BOOM

Part	Order no	Description	Remarks	Qty
1	200000534	Lifting boom		1
2	58204610	Plain bearing		2
3	52401015	Grease fitting	AR1/8	1
4	200000359	Hose fastener		4
5	52060209	Hex screw	ST8.8ZN, M10X16, DIN933	8
6	52117108	Lock nut	ST8.8ZN, M10, DIN985	8
7	200002509	Farmi Smart	sticker	2
8	200002517	CR40	sticker	2
9	41014270	Lifting point	sticker	4

CR40

200000533 FOLDING BOOM

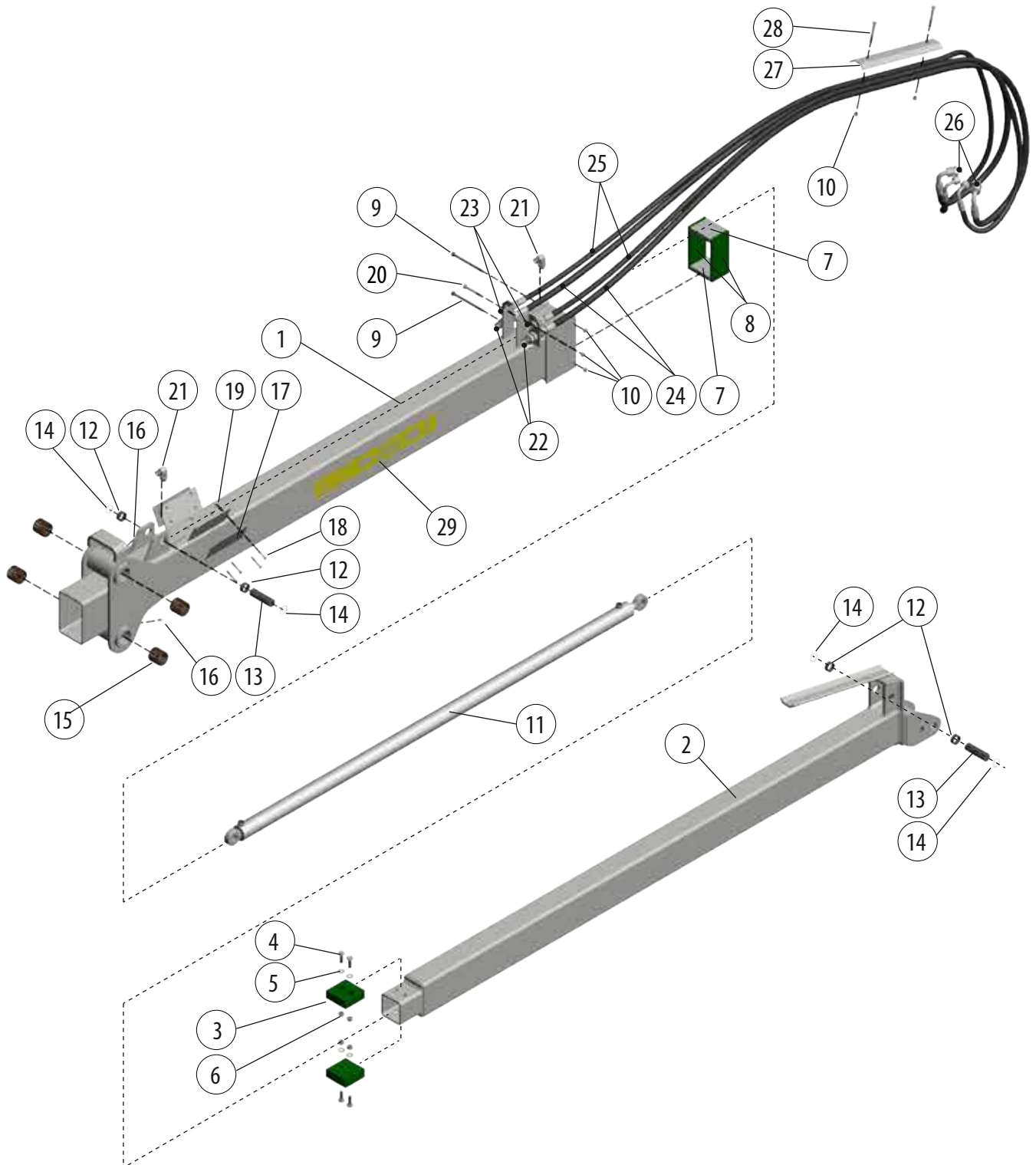

CR40

200000533 FOLDING BOOM

Part	Order no	Description	Remarks	Qty
1	200000532	Folding boom		1
2	200000531	Extension boom		1
3	200000354	Sliding part	28x80x80 mm	2
4	52060233	Hex screw	ST8.8ZN, M10X30, DIN933	4
5	52200045	Washer	ST5.8ZN, M10, DIN125	4
6	52117108	Lock nut	ST8.8ZN, M10, DIN985	4
7	200000353	Sliding part	15x70x80 mm	2
8	200000352	Sliding part	8x70x150 mm	2
9	52070745	Hex screw	ST8.8ZN, M8X120, DIN931	2
10	52117082	Lock nut	ST8.8ZN, M8, DIN985	5
11	58221300	Hydraulic cylinder	40/25-1500	1
11.1	04080690	Seal kit		1
12	200000356	Stopper sleeve		4
13	200000357	Cylinder pin		2
14	52230315	External circlip	BLACK, 25X1,2, DIN471	4
15	58204610	Plain bearing		4
16	52401023	Grease fitting	AM6	2
17	200000358	Hose fastener	6x65x150 mm	2
18	52060431	Hex screw	ST8.8ZN, M6X40, DIN931	8
19	52117066	Lock nut	ST8.8ZN, M6, DIN985	8
20	52060472	Hex screw	ST8.8ZN, M8X70, DIN931	1
21	52444820	Elbow fitting	R3/8, 90°	2
22	52435336	Feed-through nipple	ST, R1/2	2
23	52435328	Feed-through nipple	R3/8	2
24	56526320	Hose assembly	K1/2"S L2,7 m	2
25	56522329	Hose assembly	K3/8"S L=2,7 m	2
26	52432010	Double fitting	R3/8-1/2	2
27	200002574	Hose fastener		1
28	52060170	Hex screw	ST8.8ZN, M8X60, DIN931	2
29	40146720	Danger zone 20 m	sticker	2

CR40

200001719 ROTATOR CR300-W25A25

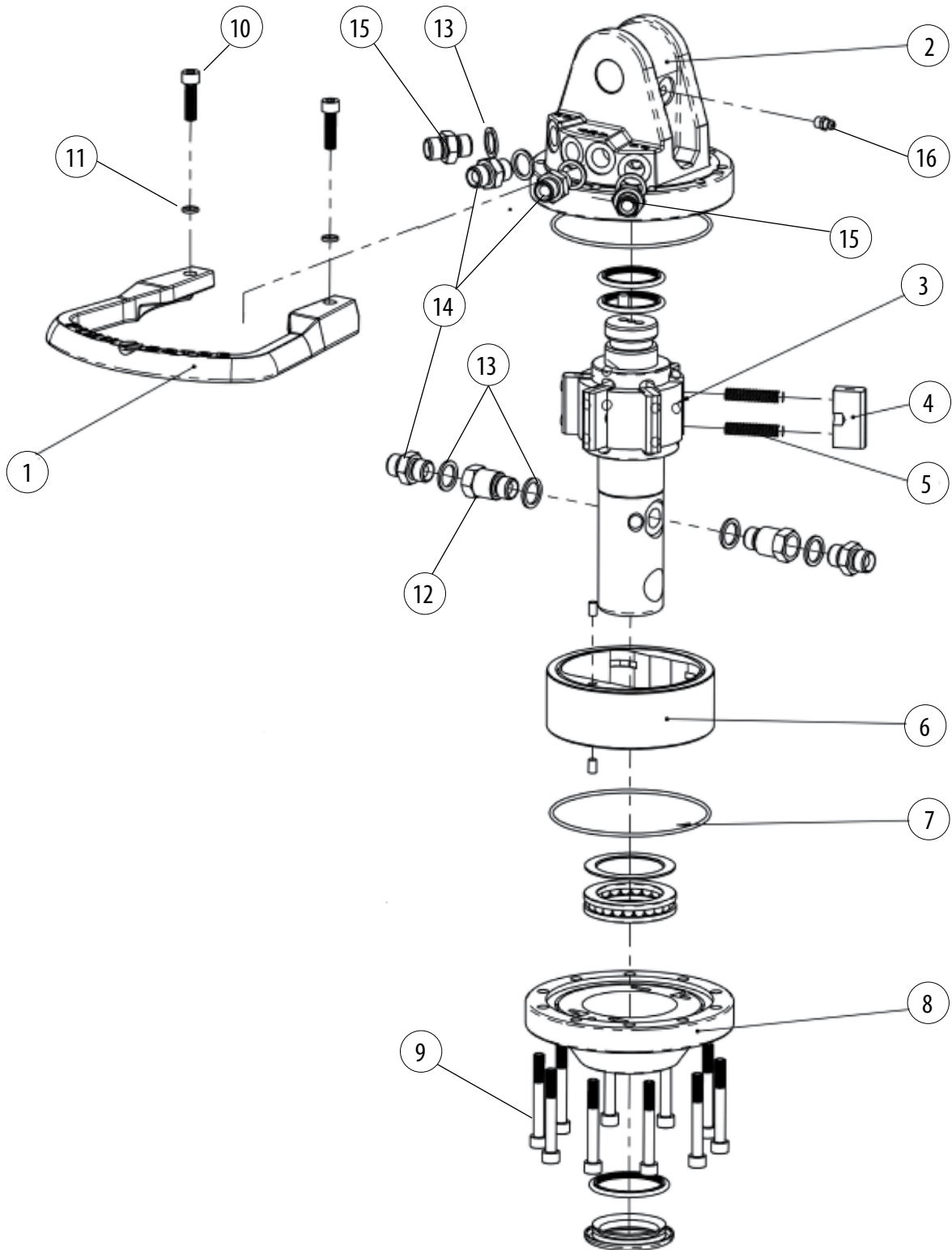

CR40

200001719 ROTATOR CR300-W25A25

Part	Order no	Description	Remarks	Qty
1	200002986	Hose cover		1
2	200002987	Top cover		1
3	200002988	Repair kit	for axle, bearing included	1
4	200002989	Plate kit	all wings included	1
5	200002990	Spring	all springs included	1
6	200002991	Chamber		1
7	200002992	Seal kit	all seal included	1
8	200002993	Lid		1
9	200002994	Hex socket cap screw	ST12.9 BLACK, M8X65, DIN 912	10
10	200002002	Hex socket cap screw	ST12.9 BLACK, M8x30, DIN912	2
11	52200037	Washer	ST5.8ZN, M8, DIN126	2
12	200003163	Extension coupling	G3/8"	2
13	52390556	Usit seal ring	R3/8"	8
14	52432028	Double fitting	R3/8	4
15	52432010	Double fitting	R3/8-1/2	2
16	200003164	Grease fitting	M8x1,25	1

CR40

200001717 CROSS LINK, WITHOUT BRAKE

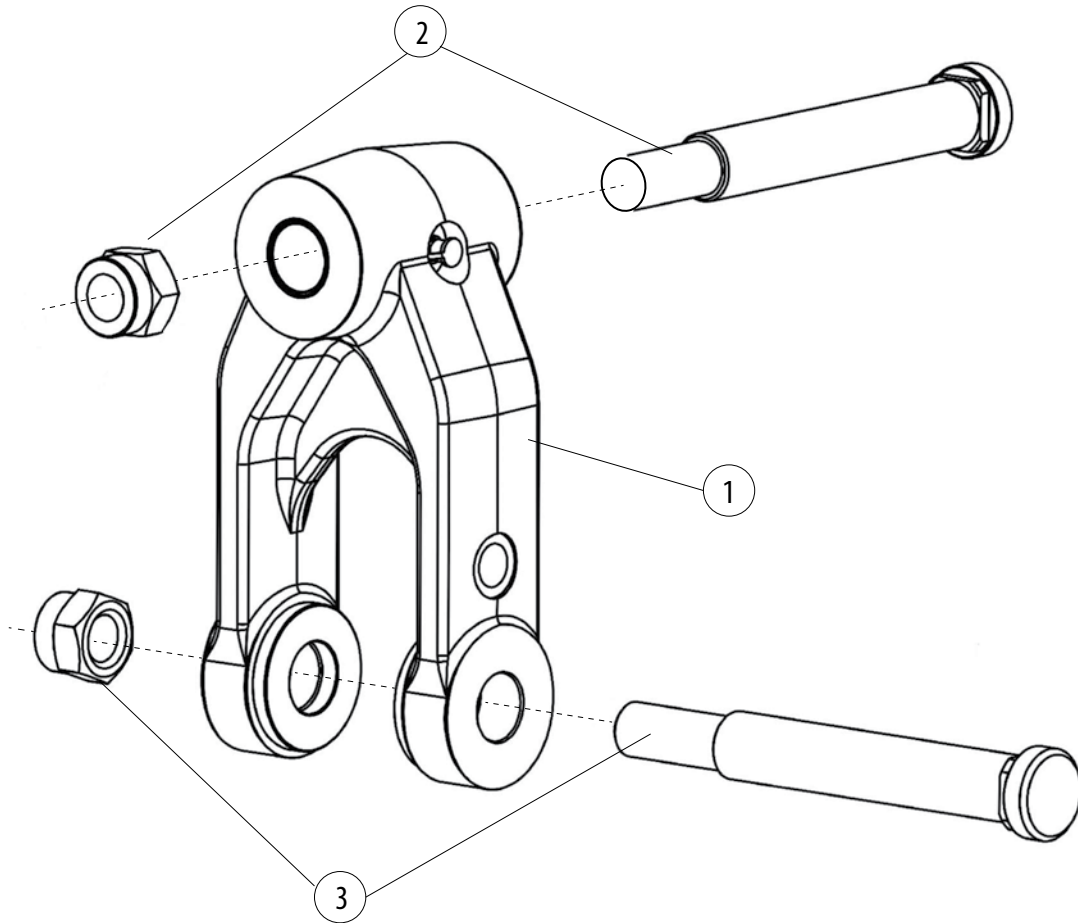

Part	Order no	Description	Remarks	Qty
1	200003014	Frame		1
2	200003015	Upper pin kit		1
3	200003016	Lower pin kit		1

CR40

200001712 CROSS LINK, WITH BRAKE

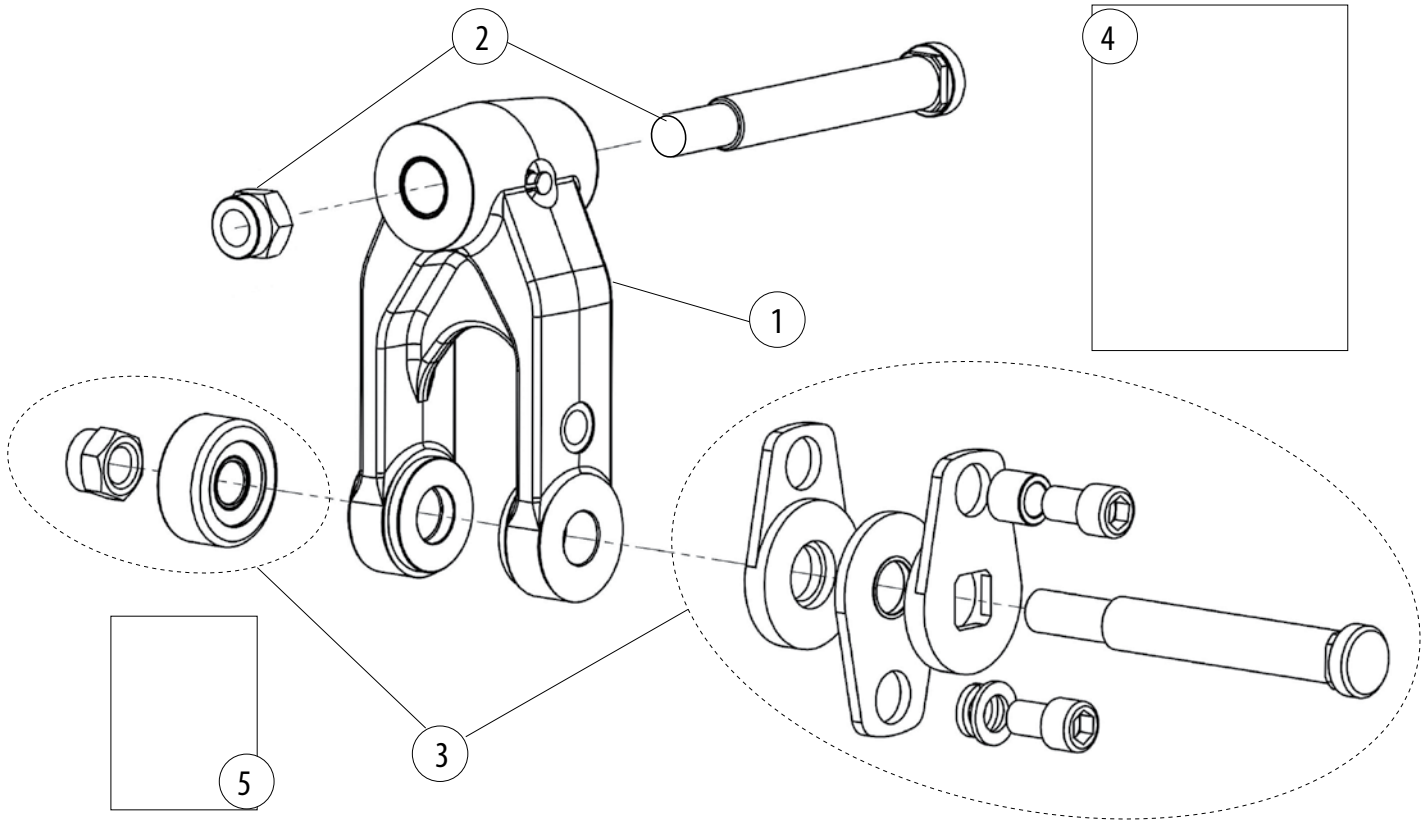

Part	Order no	Description	Remarks	Qty
1	200003014	Frame		1
2	200003015	Upper pin kit		1
3	200003017	Lower pin kit		1
4	200003018	Brake disc kit		
5	200003019	Spring kit		

CR40

200001715 CROSS LINK, WITH DUAL BRAKE

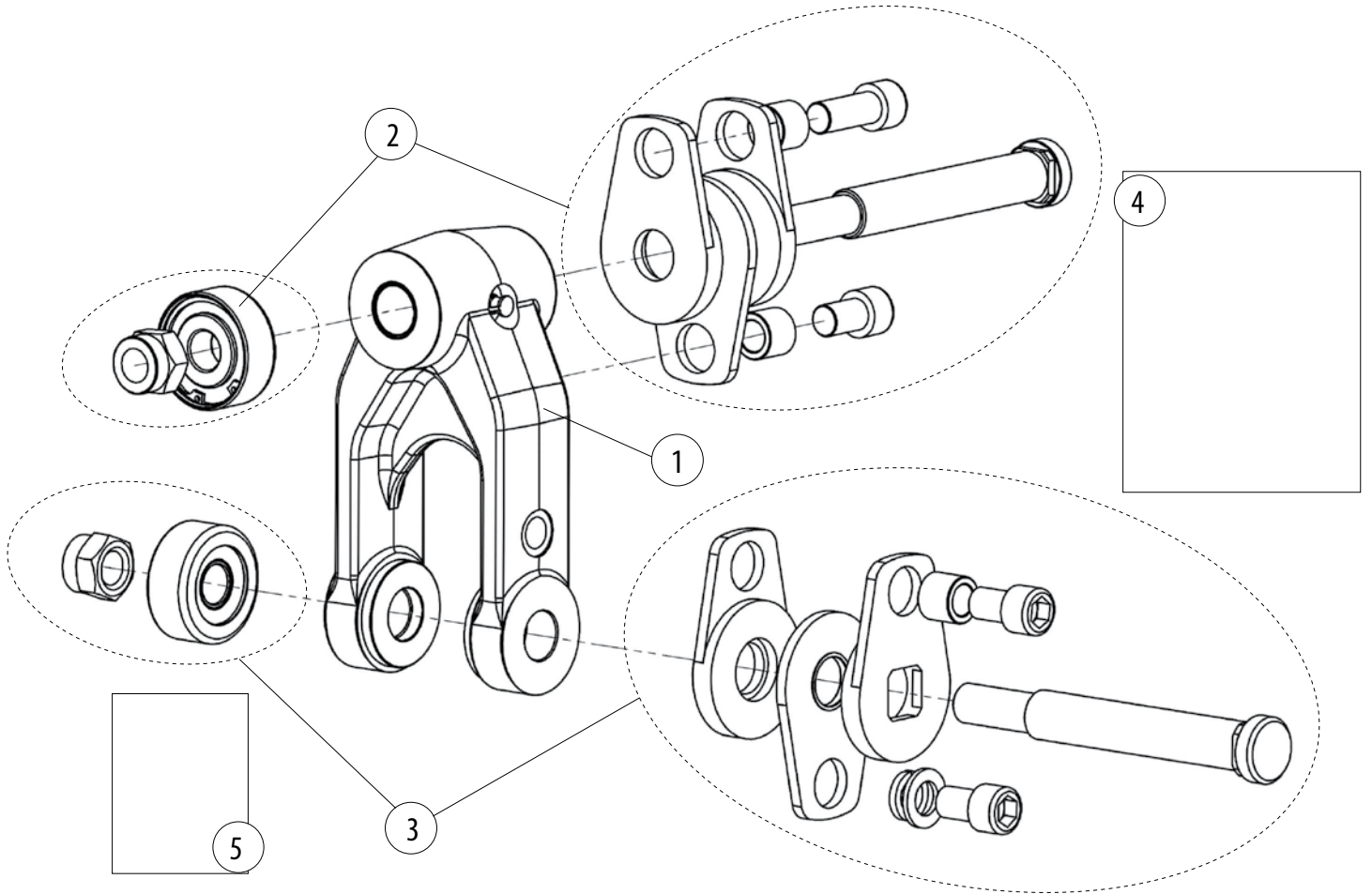

Part	Order no	Description	Remarks	Qty
1	200003014	Frame		1
2	200003020	Upper pin kit		1
3	200003017	Lower pin kit		1
4	200003018	Brake disc kit		
5	200003019	Spring kit		

CR40

200002801 TIMBER GRAPPLE PTK021S / CR300

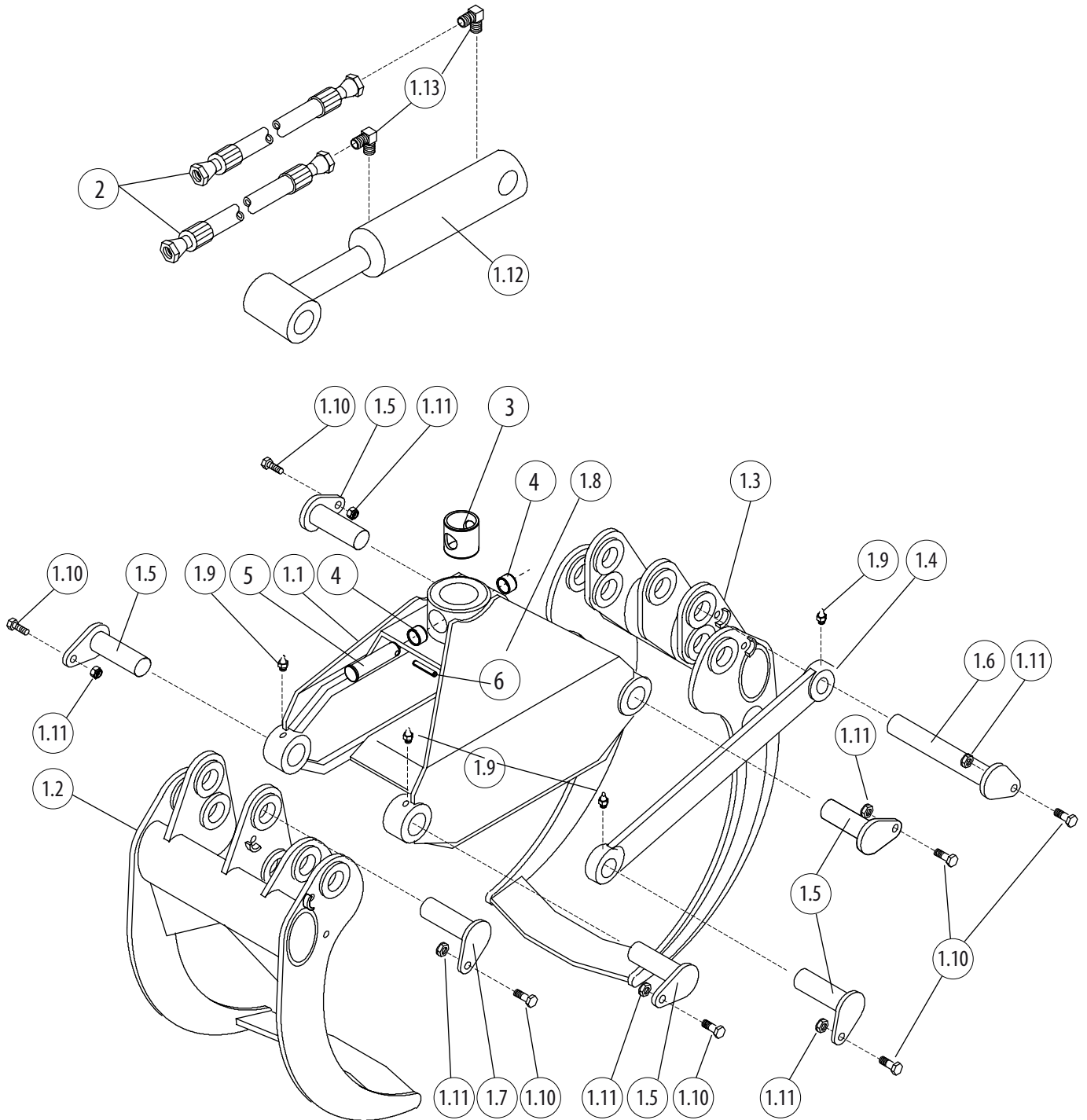

CR40

200002801 TIMBER GRAPPLE PTK021S / CR300

Part	Order no	Description	Remarks	Qty
1	23595050	Timber grapple		1
1.1	43595310	Frame		1
1.2	13282058	Jaw	inner jaw	1
1.3	13282090	Jaw	outer jaw	1
1.4	23282023	Lever		1
1.5	43281930	Joint pin		5
1.6	43281955	Cylinder pin		1
1.7	43281971	Cylinder pin		1
1.8	40147090	Farmi forest	sticker	1
1.9	52401015	Grease fitting	AR1/8	6
1.10	52060233	Hex screw	ST8.8ZN, M10X30, DIN933	7
1.11	52117108	Lock nut	ST8.8ZN, M10, DIN985	7
1.12	56097220	Hydraulic cylinder	70/40-196	1
1.13	52442357	Elbow fitting	RK3/8-R3/8 UK, 90°	2
1.14	40147370	Machine plate		1
2	56521065	Hose assembly	V3/8"S L=0,55 m	2
3	43287945	Adapter sleeve		1
4	200002807	Adapter sleeve		2
5	200002815	Pin		1
6	52840220	Spring pin	8X50, DIN1481	1

CR40

200001965 HYDRAULIC SUPPORT LEGS, 3-POINT LINKAGE

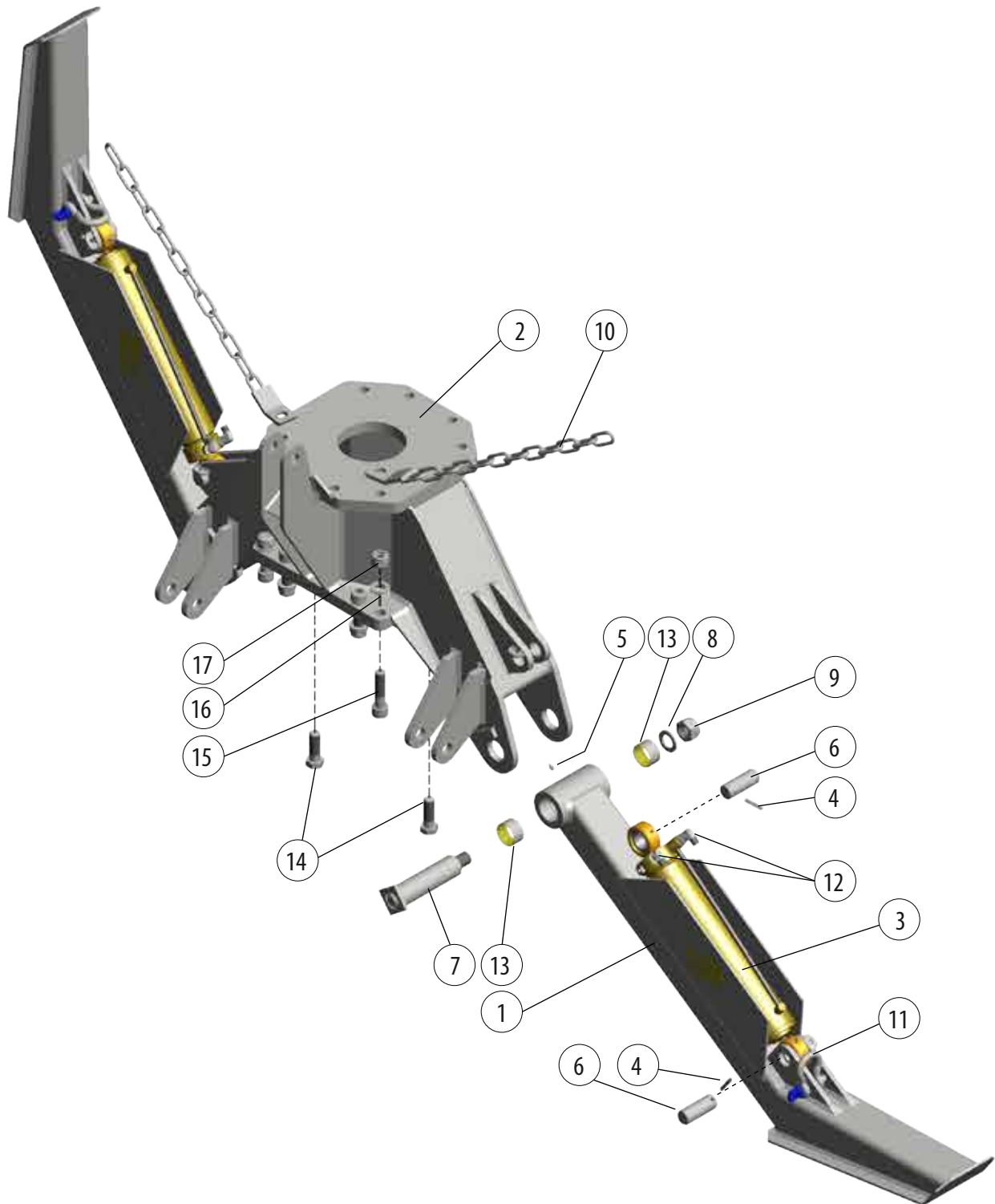

CR40

200001965 HYDRAULIC SUPPORT LEGS, 3-POINT LINKAGE

Part	Order no	Description	Remarks	Qty
1	200001964	Support leg		2
2	200001963	Trestle		1
3	56096070	Hydraulic cylinder	70/50-360, -, PN35, R3/8"	2
4	52840220	Spring pin	8X50, DIN1481	4
5	52401023	Grease fitting	AM6	2
6	44082090	Cylinder pin		4
7	44082320	Pin		2
8	52200110	Washer	ST5.8ZN, M30, DIN126	2
9	52117306	Lock nut	ST8.8ZN, M30, DIN985	2
10	43492670	Chain		2
11	54815147	Wire rope lock		2
12	52444820	Elbow fitting	R3/8, 26-04500-06, 90°	4
13	54562442	Plain bearing	PM 5030 DX, CLACIER	4
14	52064673	Hex screw	ST10.9ZN, M24X2X70, DIN960	2
15	200002080	Hex screw	ST8.8ZN, M24X90, DIN931	6
16	52200102	Washer	ST5.8ZN, M24, DIN126	6
17	52117249	Lock nut	ST8.8ZN, M24, DIN985	6

WARRANTY

Farmi Forest Oy grants a 12-month warranty on all of its products, covering material and manufacturing faults. The warranty comes into effect on the product's delivery date.

The manufacturer is not liable for damages caused by:

- misuse of the product
- alterations or repairs made without the manufacturer's permission
- insufficient maintenance
- non-original parts

The warranty does not cover wearing parts.

Send faulty parts, carriage paid, to the manufacturer for inspection. Repairs will be conducted by Farmi Forest Oy or an authorized expert. The warranty is valid only if the bottom part of this page is filled in and returned to the manufacturer within 30 days of receipt of the product. By returning the warranty certificate, you confirm that you have read and understood the instruction manual that came with the product.



Farmi Forest Corporation
Ahmolantie 6
FIN-74510 IISALMI
FINLAND



PRODUCT REGISTRATION FORM

Date of delivery: ____/____ 20____

Dealer: _____

Dealer's address: _____

Dealer's tel: _____

Product and type: _____

Serial number: _____

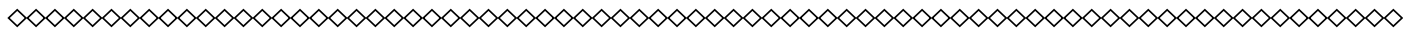

Return to the manufacturer



Date of delivery: ____/____ 20____

Dealer: _____

Dealer's address: _____

Dealer's tel: _____

Customer: _____

Customer's address: _____

Customer's tel: _____

E-mail: _____

Product and type: _____

Serial number: _____





Farmi Forest Corporation
Ahmolantie 6
FIN-74510 Iisalmi, Finland
Tel. +358 (0)17 83 24 400
info@farmiforest.fi
www.farmiforest.fi